



2505 Dekko Drive
Garrett, IN 46738
Customer Service: 800.357.5622

ASHLEY DUO UNDER - Conduit Feed -

Under Worksurface Mounting

Installation Instruction

This device complies with part 15 of the FCC Rules. Operation is subject to the following two conditions: (1) This device may not cause harmful interference, and (2) this device must accept any interference received, including interference that may cause undesired operation.

Tools Required



1 Place Template and Pre-Drill Holes

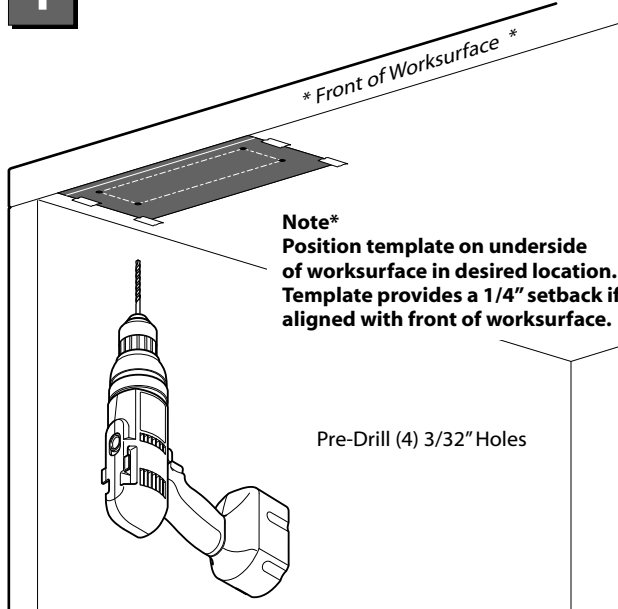

2 Install Ashley Duo Under to Worksurface

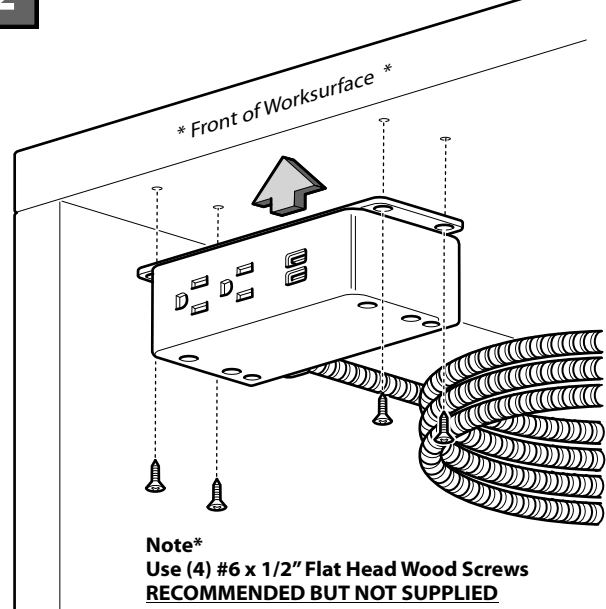

3 Route Conduit Feed to Nearest Power Distribution Source

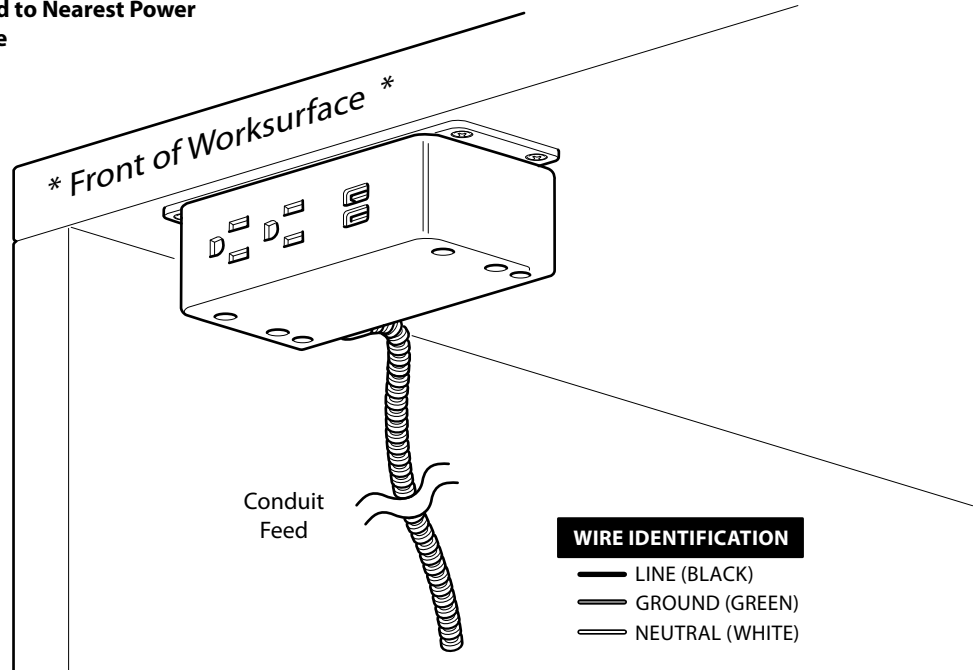



2505 Dekko Drive
Garrett, IN 46738
Customer Service: 800.357.5622

ASHLEY DUO UNDER - Conduit Feed -

Under Worksurface Mounting

Drilling Template

This device complies with part 15 of the FCC Rules. Operation is subject to the following two conditions: (1) This device may not cause harmful interference, and (2) this device must accept any interference received, including interference that may cause undesired operation.

