

2505 Dekko Drive  
Garrett, IN 46738  
Customer Service: 800.357.5622

# WEDGE

(Patent Pending)  
- Conduit -  
Surface Mounting  
Installation Instruction

This device complies with part 15A of the FCC Rules. Operation is subject to the following two conditions: (1) This device may not cause harmful interference, and (2) this device must accept any interference received, including interference that may cause undesired operation.

Tools Required

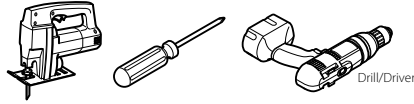

## 1 Cutout Opening for Wedge Assembly

**\* NOTE \***

Max Radius on Cutout Corners is 1/4"

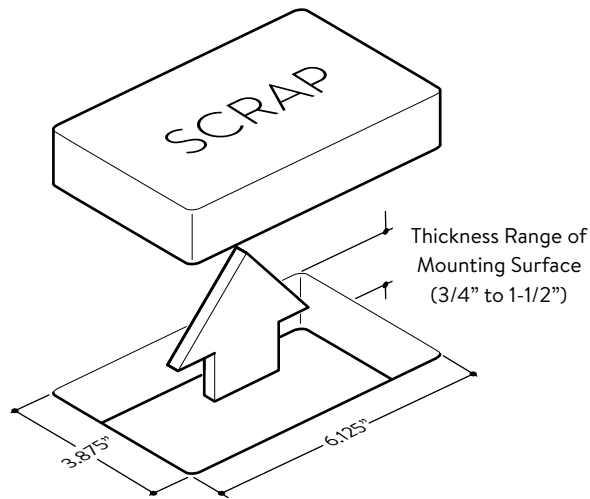

## 2 Install Wedge Assembly into Cutout

**\* NOTE \***

Route "Conduit" Through Cutout Before Inserting Assembly into Cutout.

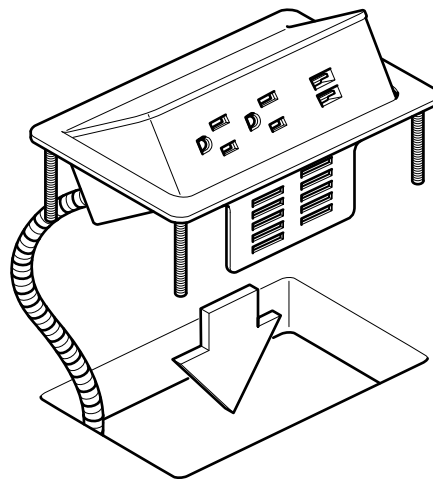

## 3 Install Wingnuts on the Threaded Studs Below the Worksurface

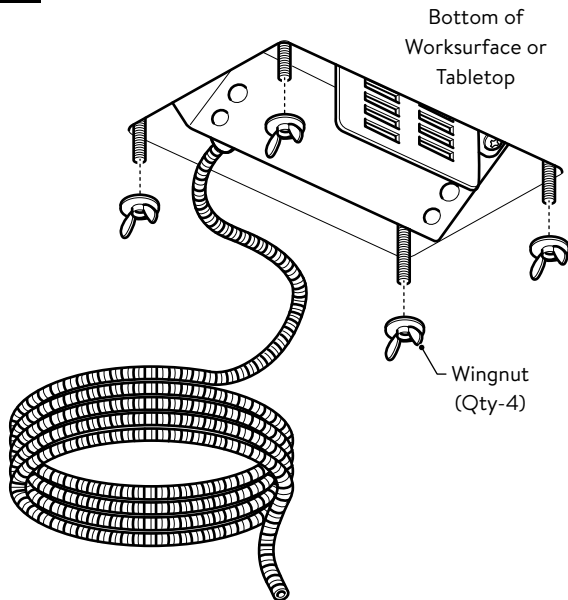

## 4 Install Locking Tab into Bracket for Tightest Fit and Route Conduit to Nearest Power Distribution

**\* NOTE \***

Pre-drill a Hole for Locking Tab Screw once Tab is Engaged with Slots in Bracket.

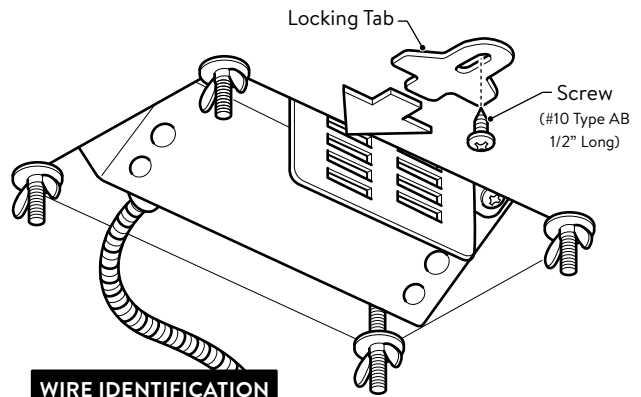

**WIRE IDENTIFICATION**

- LINE (BLACK)
- GROUND (GREEN)
- NEUTRAL (WHITE)