



7310 Innovation Blvd., Suite 104,
Fort Wayne, IN 46818
Customer Service: 800.829.3101

Powered by Pent®
ASHLEY 202
- Corded -
Above Worksurface Mounting
Installation Instruction

This device complies with part 15A of the FCC Rules. Operation is subject to the following two conditions: (1) This device may not cause harmful interference, and (2) this device must accept any interference received, including interference that may cause undesired operation.

Tools Required

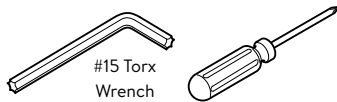

2.1 Install VGA Option (L-COM# DGBV15F)

A Remove Nuts from VGA Connector

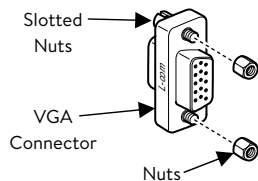

B Install Bracket to Connector

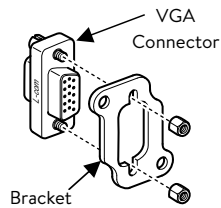

C Install Components into Body of Unit

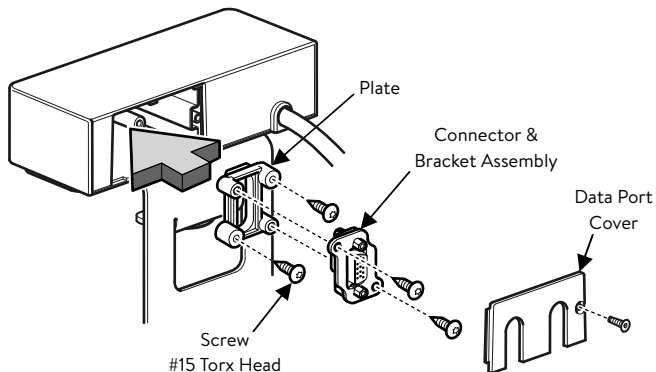

2.2 Install RJ45 Option (L-COM# TDG1026A-8C)

A Mate Angled Surfaces of Plate and Connector

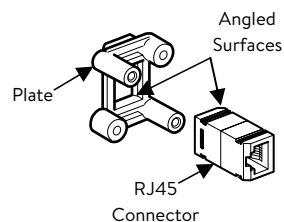

B Install Bracket

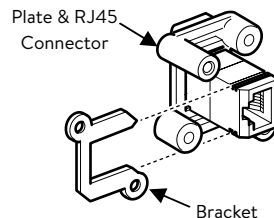

C Install Components into Body of Unit

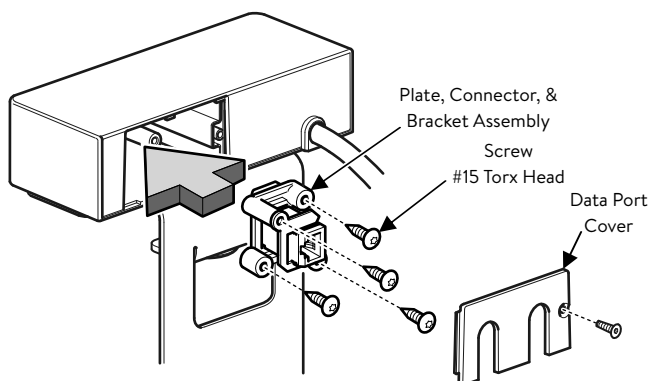

2.3 Install HDMI Option (L-COM# HДФF)

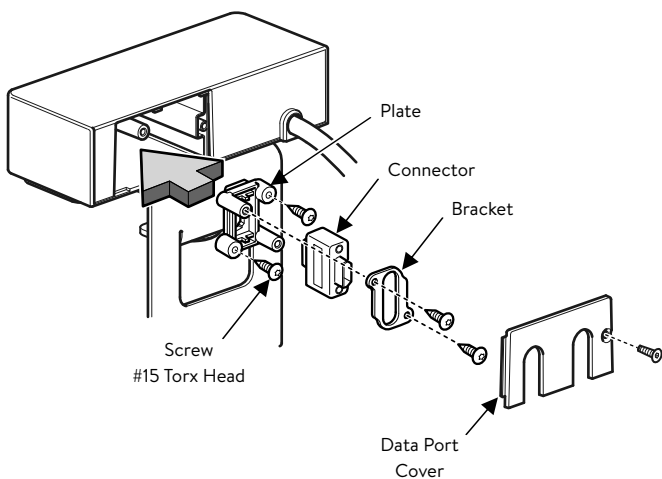

2.4 Install BLANK Option

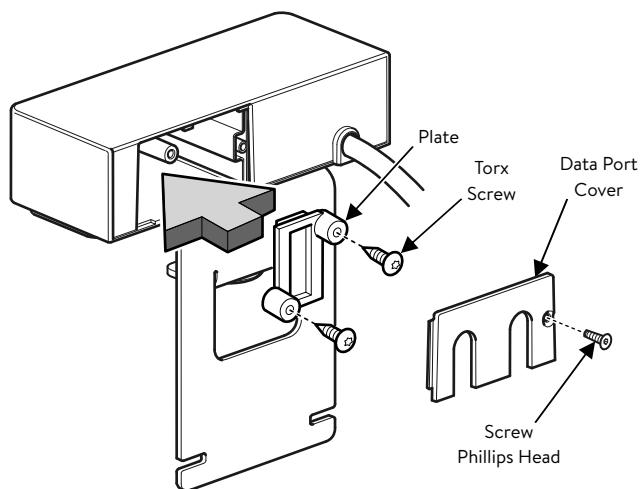



7310 Innovation Blvd., Suite 104,
Fort Wayne, IN 46818
Customer Service: 800.829.3101

Powered by Pent®
ASHLEY 202
- Corded -
Above Worksurface Mounting
Installation Instruction

This device complies with part 15A of the FCC Rules. Operation is subject to the following two conditions: (1) This device may not cause harmful interference, and (2) this device must accept any interference received, including interference that may cause undesired operation.

Tools Required



#15 Torx
Wrench

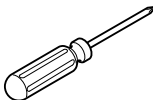

Screwdriver needed for optional
power cord mounting clamps.

5 **Secure Thumb Screws and Route Power Cord Option to Nearest Power Distribution Source**

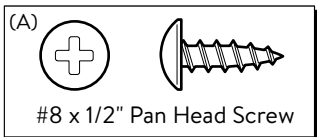

* Underside of Worksurface *

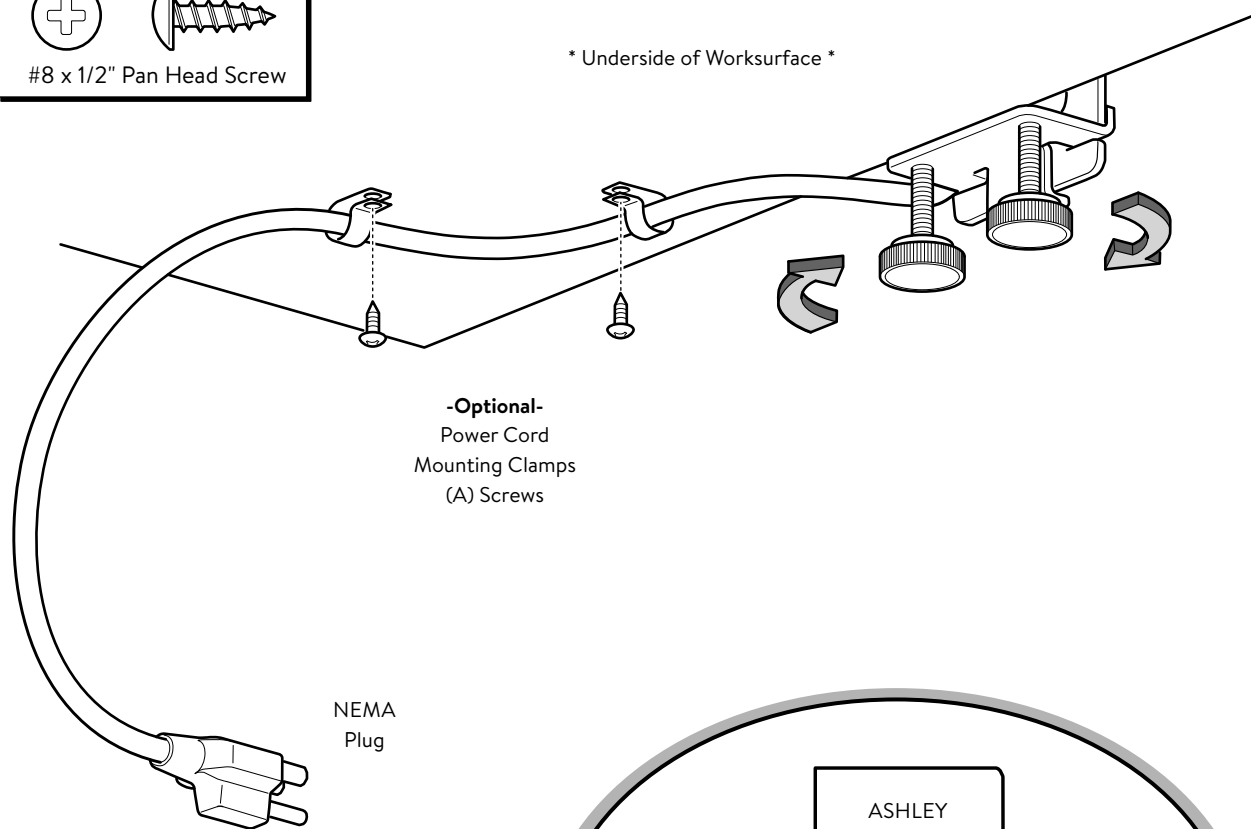

Worksurface
Thickness Range
(3/4" to 1-1/2")

