

STU  
DIO

BY DEKKO

2505 Dekko Drive  
Garrett, IN 46738  
Customer Service: 800.357.5622

# ASHLEY 202 UNDER

- Corded -

## Under Worksurface Mounting Installation Instruction

This device complies with part 15A of the FCC Rules. Operation is subject to the following two conditions: (1) This device may not cause harmful interference, and (2) this device must accept any interference received, including interference that may cause undesired operation.

### Tools Required

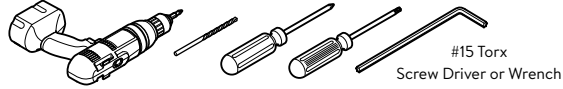

### \*NOTE\*

All Tech Adapters Need to be Mounted in the  
↑ "UP" ↑ Position. (Refer to the back of Parts)

## 1 Remove Data Port Cover and Blank Adapters

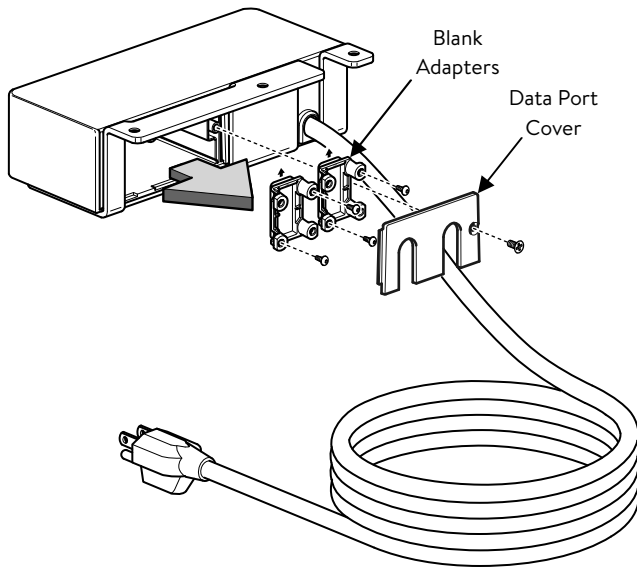

## 2 Install Data Port Options - (VGA, RJ45, HDMI, BLANK)

### \*NOTE\*

See Sheet #2 for Detailed Instructions

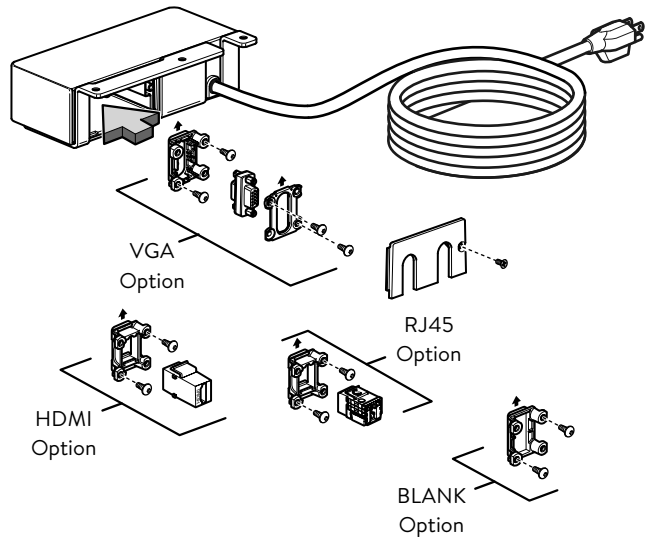

## 3 Place Template and Pre-Drill Holes

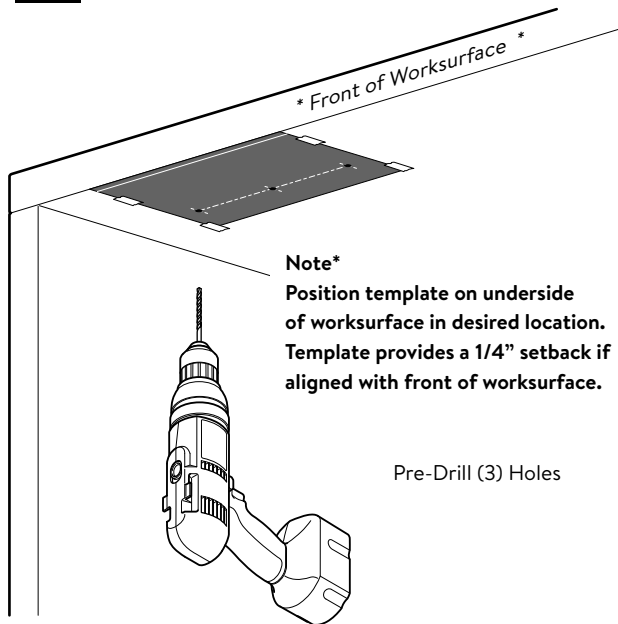

Note\*  
Position template on underside  
of worksurface in desired location.  
Template provides a 1/4" setback if  
aligned with front of worksurface.

Pre-Drill (3) Holes

## 4 Install Ashley 202 Under to Worksurface

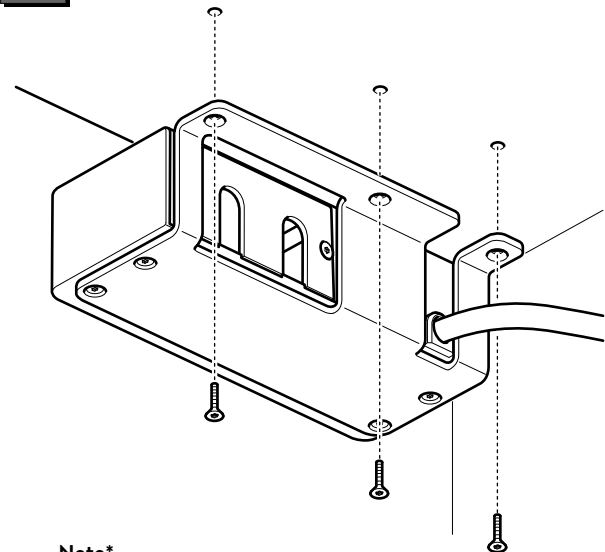

### Note\*

Use (3) #6 x 1/2" Flat Head Wood Screws  
**RECOMMENDED BUT NOT SUPPLIED**

E.C.N. No: GD17-002662

Part Number: G110183

Page Number: 1 of 4

Revision: B

# ASHLEY 202 UNDER

- Corded -

## Under Worksurface Mounting Installation Instruction

This device complies with part 15A of the FCC Rules. Operation is subject to the following two conditions: (1) This device may not cause harmful interference, and (2) this device must accept any interference received, including interference that may cause undesired operation.

### Tools Required

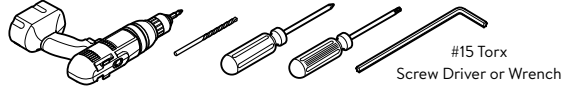

### \*NOTE\*

All Tech Adapters Need to be Mounted in the  
↑ "UP" ↑ Position. (Refer to the back of Parts)

## 2.1 Install Data Tech Adapter Option

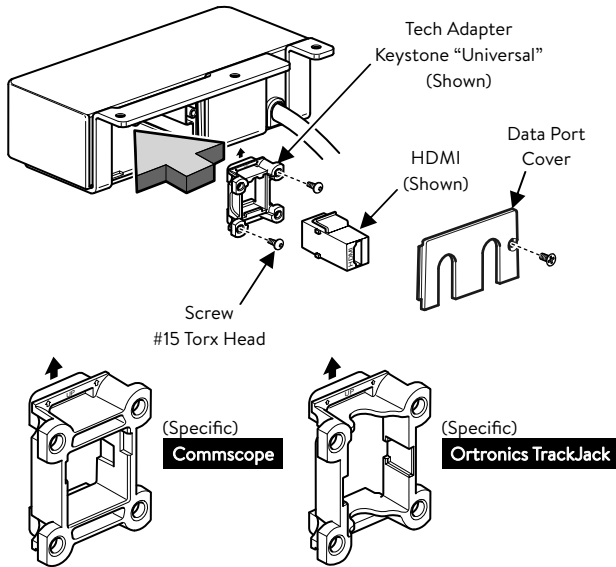

(Universal)

### KEYSTONE

HDMI	Optical Cable Corp 5e
Tripp-Lite	Optical Cable Corp 6
Allen-Tel	Ortronics
AMP TE-Krone	Panduit NetKey
Belden KeyConnect	Hubbell Premise
Leviton Quick Port	Type F Coax
Leviton Quick Port Extreme	ETC. (ET. AL.)

## 2.2 A Install VGA Connector to VGA Tech Adapters

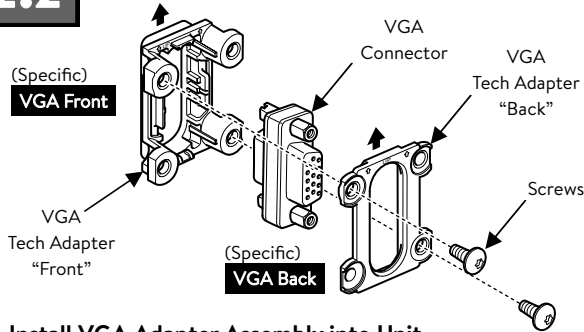

## B Install VGA Adapter Assembly into Unit

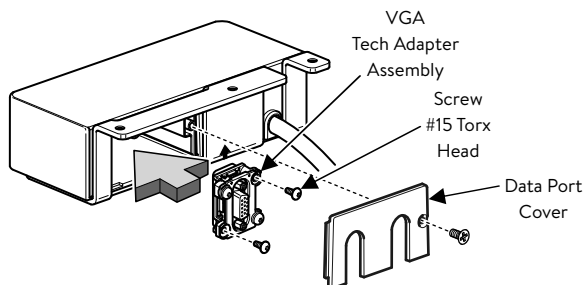

## 2.3 Install Blank Tech Adapter Option

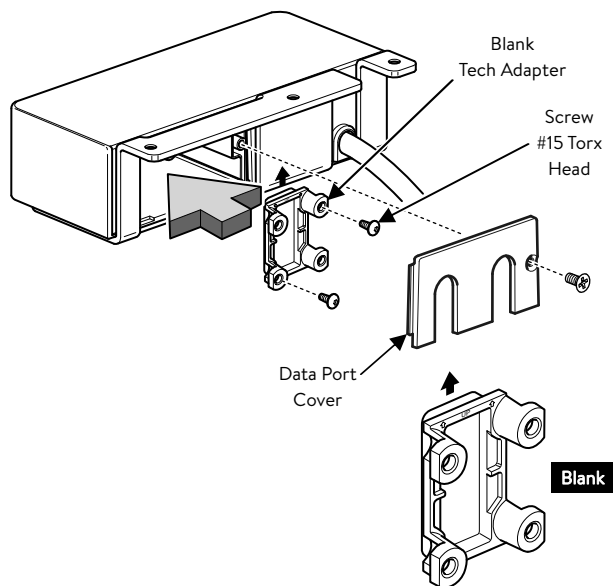

STU  
DIO

BY DEKKO

2505 Dekko Drive  
Garrett, IN 46738  
Customer Service: 800.357.5622

# ASHLEY 202 UNDER

- Corded -

## Under Worksurface Mounting Installation Instruction

This device complies with part 15A of the FCC Rules. Operation is subject to the following two conditions: (1) This device may not cause harmful interference, and (2) this device must accept any interference received, including interference that may cause undesired operation.

### Tools Required

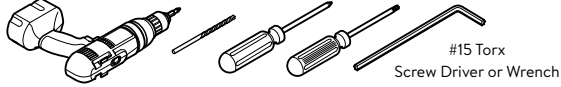

### \*NOTE\*

All Tech Adapters Need to be Mounted in the  
⬆ "UP" ⬆ Position. (Refer to the back of Parts)

5

### Route Power Cord Option to Nearest Power Distribution Source

(A)

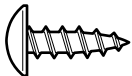

#8 x 1/2" Pan Head Screw

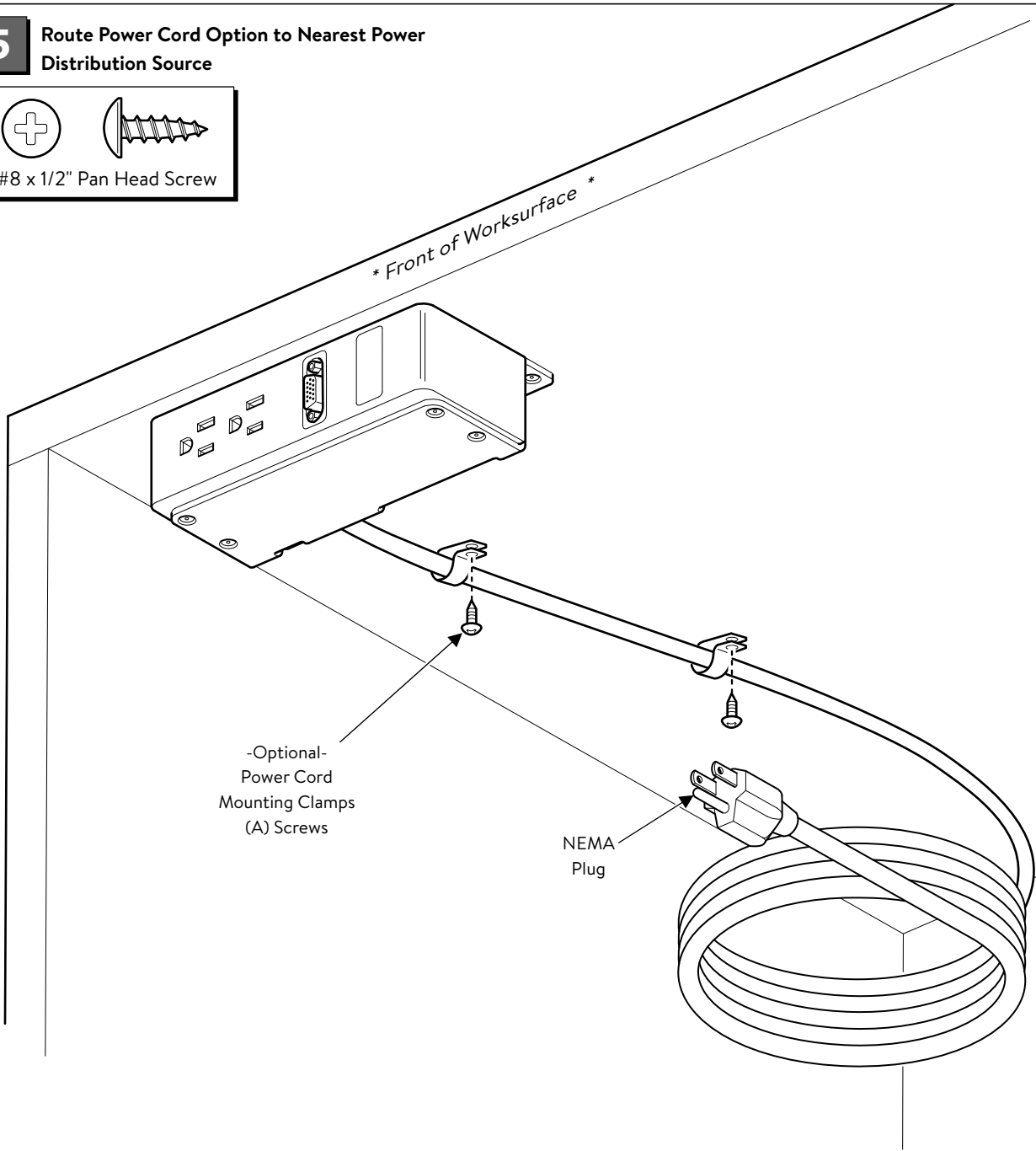



BY DEKKO

2505 Dekko Drive  
Garrett, IN 46738  
Customer Service: 800.357.5622

# ASHLEY 202 UNDER

- Corded -

**Under Worksurface Mounting**  
Installation Instruction Template

This device complies with part 15A of the FCC Rules. Operation is subject to the following two conditions: (1) This device may not cause harmful interference, and (2) this device must accept any interference received, including interference that may cause undesired operation.

