



2505 Dekko Drive
Garrett, IN 46738
Customer Service: 800.357.5622

ASHLEY DUO AIR

- Conduit Feed -
Surface Mounting
Installation Instruction

This device complies with part 15A of the FCC Rules. Operation is subject to the following two conditions: (1) This device may not cause harmful interference, and (2) this device must accept any interference received, including interference that may cause undesired operation.

Tools Required

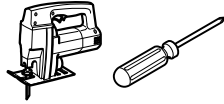

1 Cutout Opening for Ashley Duo Air Assembly

*** NOTE ***

Please use Template Provided on Page 2.
Max Radius on Cutout Corners is 1/4"

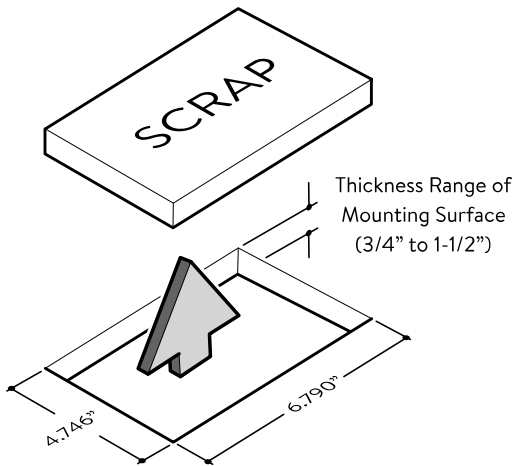

2 Install Ashley Duo Air Assembly into Cutout

*** NOTE ***

Route "Conduit" Through Cutout Before Inserting Assembly into Cutout.

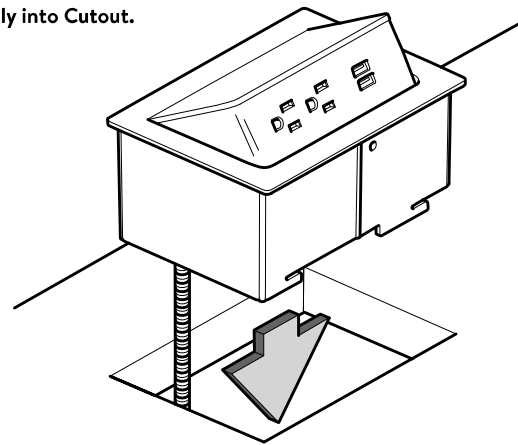

3 Install Retainer Bracket

Underside of Worksurface

* Align Tabs on Ashley Duo Air Assembly with Slots on Retainer Bracket and Slide into Fully Engaged Position *

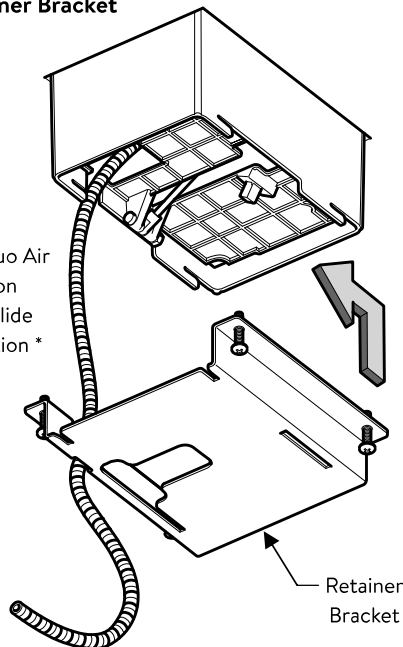

*** NOTE ***

Route Conduit Through Notch in Retainer Bracket

4 Route Connector to Nearest Power Distribution Source

* Tighten Screws Snug to the Bottom of the Worksurface (Qty-4) *

Underside of Worksurface

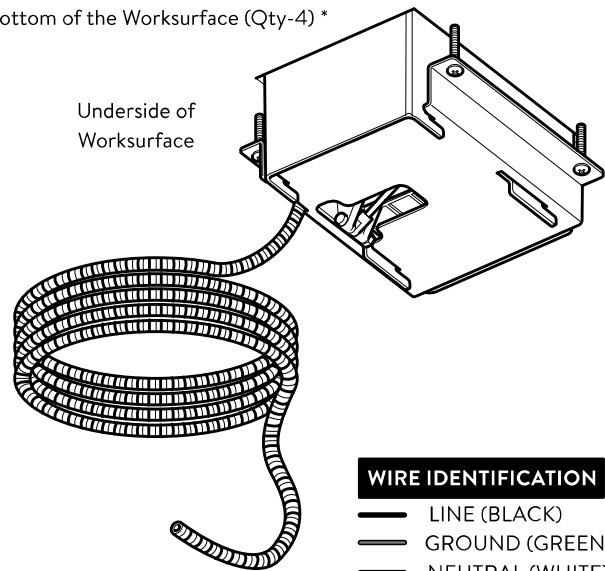

WIRE IDENTIFICATION
 — LINE (BLACK)
 — GROUND (GREEN)
 — NEUTRAL (WHITE)

E.C.N. No: GD18-003196

Part Number: G110318

Page Number: 1 of 2

Revision: A



2505 Dekko Drive
 Garrett, IN 46738
 Customer Service: 800.357.5622

ASHLEY DUO AIR
 - Conduit Feed -
 Surface Mounting
Installation Instruction Template

This device complies with part 15A of the FCC Rules. Operation is subject to the following two conditions: (1) This device may not cause harmful interference, and (2) this device must accept any interference received, including interference that may cause undesired operation.

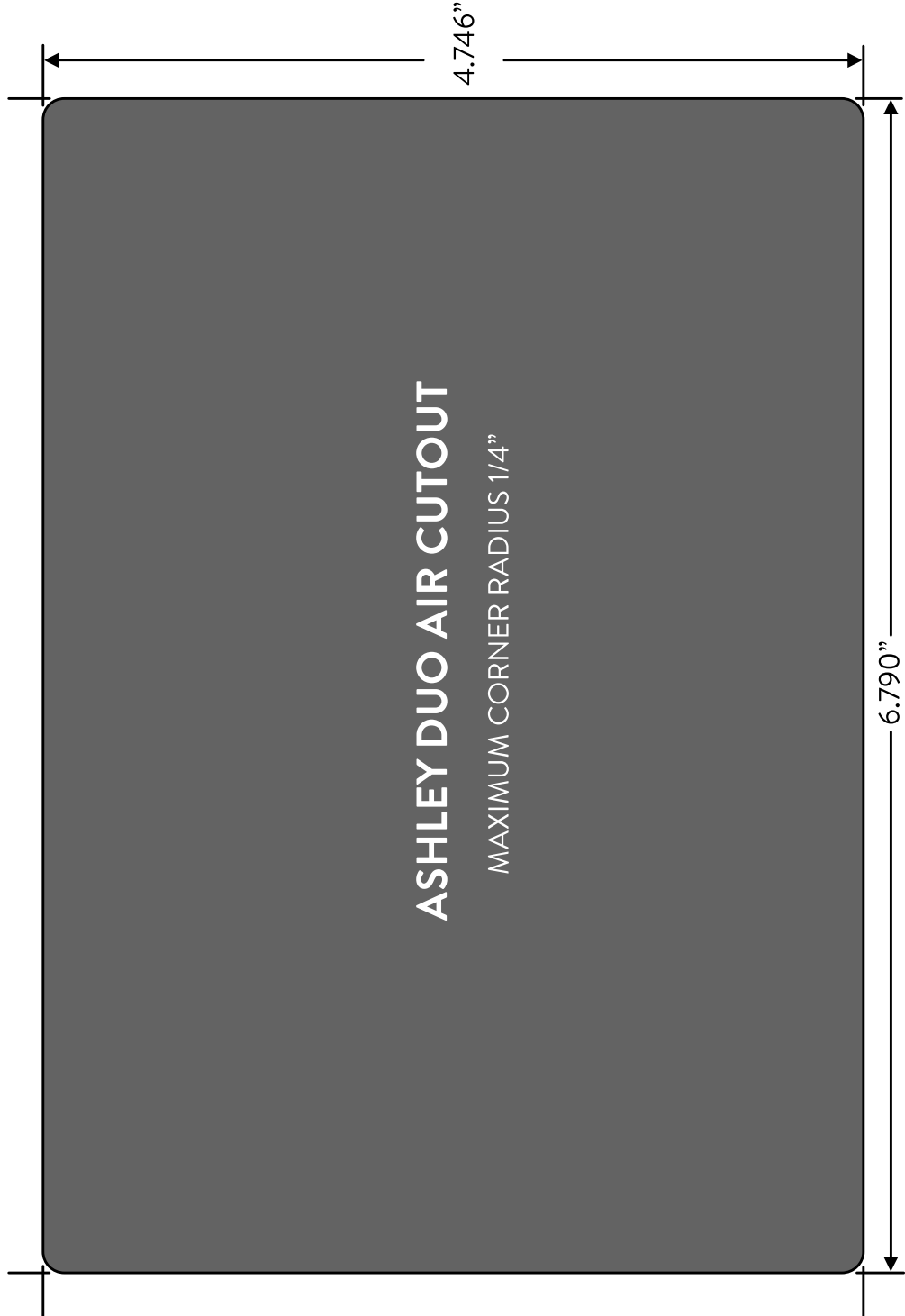

E.C.N. No: GD18-003196

Part Number: G110318

Page Number: 2 of 2

Revision: A



POWER AND DATA



Uncontrolled Copy