

INTERCEPT 1 INSTALLATION

Components & Hardware

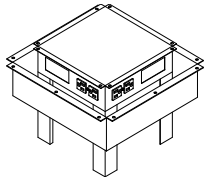

(A) Intercept
Qty 1



(B) Mounting Screws
#10 x .50"
Qty 20



(C) Brush Mount Screw
#4 x .25"
Qty 12

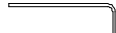

(E) Wrench
Qty 1



(D) Brush
Qty 4

Tools Needed



For use with: Do not use provided screws on table thicknesses less than .75"

Table Thickness: .75" – 1.625"

Table Cutout: 13.125" x 13.125" (finished dimension)

Cutout Piece Size: 11.625 x 11.625" (finished dimension)#

*Use caution not to pierce top surface with screws.

If Brushes (D) or AK-99 is to be used

1- Prepare table per instructions on Table preparation Sheet. Be sure to retain portion of cutout table top if it is intended to be finished top of Intercept 1 (A).

2- Table Thickness Adjustment – The Inner Pan has four adjustable mounting flanges that must be set for the specific table thickness the Intercept is being installed into, see detail. To adjust remove lock nuts, 2 per flange, and move flange to the correct hole that corresponds to the table thickness. Reinstall and tighten lock nuts to secure flanges into pan.

3- Table Cutout Mounting – Attach Cutout Piece, from Table Preparation Sheet (9065-0003), to top of main housing using Mounting Screws (B)*. Each screw will go thru hole in housing top flange and into pilot hole in Cutout Piece.

4- Intercept Mounting – Secure the Intercept to the underside of table, as shown, using Mounting Screws (B)*. Note: Center Intercept on table cutout.

5- Brush Mounting – Secure 4 Brushes (D) around table opening using Brush Mount Screws (C). Note: Brushes are mitered in corners. Use care to ensure Brushes are flush to top surface and square in corners.

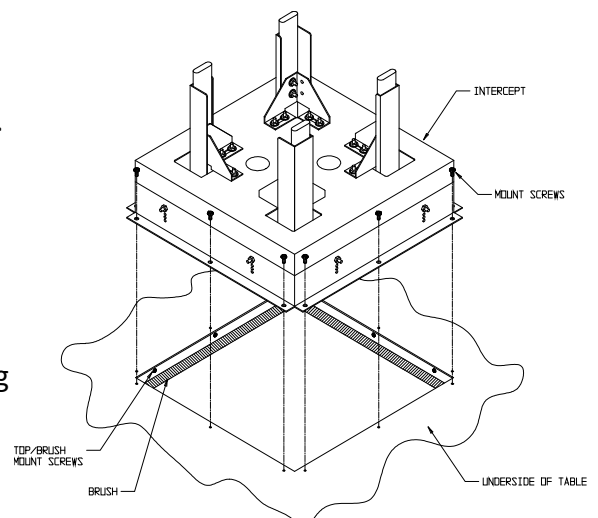
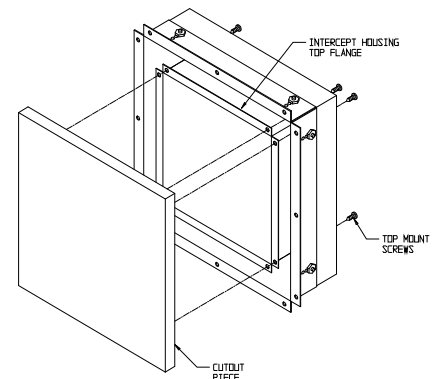
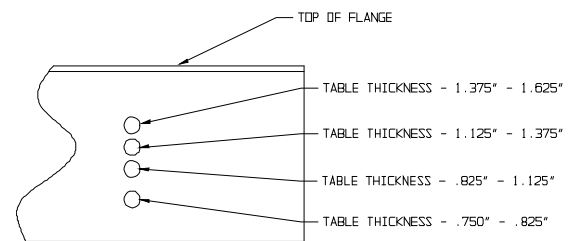

INTERCEPT 1 INSTALLATION

6- Intercept Adjustment – The Intercept can be adjusted to make the Cutout Piece centered in Brushed and flush with table top.

6A - Horizontal Adjustment – There are 12 horizontal adjustment screws on the underside of the Intercept. To center the Cutout Piece within the brushes or table cutout loosen the horizontal adjustment screws, Note: do not remove screws or Intercept will fall from mounted location, and move as required to center in opening. Tighten screws when finished.

6B – Vertical Adjustment – There are 8 vertical adjustment screws on Intercept housing, 2 per face. To make top of Cutout piece flush with table surface loosen vertical adjustment screws with wrench (E) as required and shift Cutout Piece as needed. Tighten screws when done.

7- Install Data – Install data as required by snapping A-Plates into housing cutouts and feed cables thru shutter bushings in housing and down thru openings in inner pan. Note: Do not run cables thru latch opening. This will prevent Intercept from operating and may damage Intercept. When routing data wire make sure to provide a service loop so Intercept can fully operate up and down without damaging cables.

8- Connect Power – Connect Intercept to power as required. Be sure power cord is not routed where it will become damaged during Intercept movement up and down.

9- Test Operation – Test operation of Intercept by pressing down on center of Cutout Piece to release and raise Intercept. Repeat to engage and close. Be sure that all wires are routed out of all moving parts, and that wires do not restrict smooth and complete movement of Intercept.

Safety Note: Because the Intercept has exposed moving parts it is intended to be mounted within an enclosure or pedestal. If it is not, an Outer Pan Enclosure is available and should be used to prevent injury.

