



2505 Dekko Drive  
Garrett, IN 46738  
Customer Service: 800.357.5622

# PERIMETER SYSTEM

## Installation Instruction

The Perimeter System is a UL 962 recognized electrical system intended to be paired with furniture for a UL 962 listing.

### Tools Required

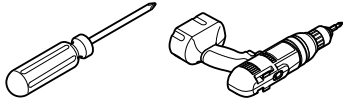

### 1 Arrange Tables in Desired Location

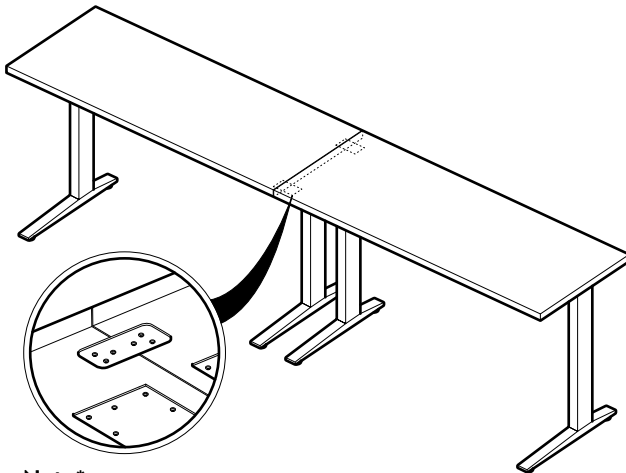

**Note\***  
It is recommended to mechanically gang tables together per manufacture's instructions once arrangement is complete.

### 2 Install Power Modules Where Desired

**Note\***  
Perimeter System also supports many other Studio Power Distribution products. Some of the other products are shown below.

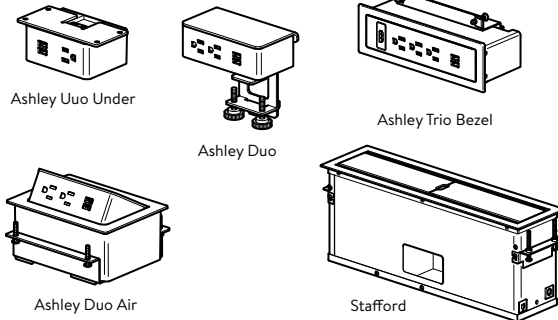

**Note\***  
Please refer to individual Power Module Installation Instructions for assembly. (See Website)

### 3 Install Device Jumpers between Power Modules

**Note\***  
Connectors are keyed and plug in one way only.

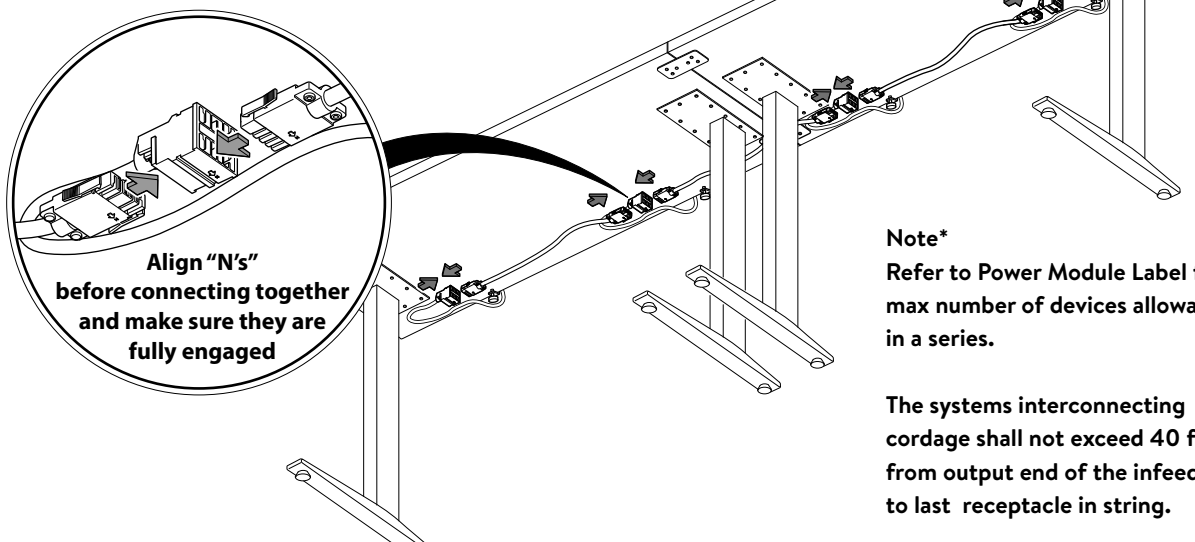

**Note\***  
Refer to Power Module Label for max number of devices allowable in a series.

The systems interconnecting cordage shall not exceed 40 feet from output end of the infeed box to last receptacle in string.



2505 Dekko Drive  
Garrett, IN 46738  
Customer Service: 800.357.5622

# PERIMETER SYSTEM

## Installation Instruction

The Perimeter System is a UL 962 recognized electrical system intended to be paired with furniture for a UL 962 listing.

### Tools Required

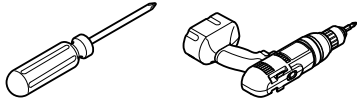

#### 4 Install Cord Supports

**Note\***  
Cord supports should be located close to connectors and then positioned a minimum of every 2 feet.

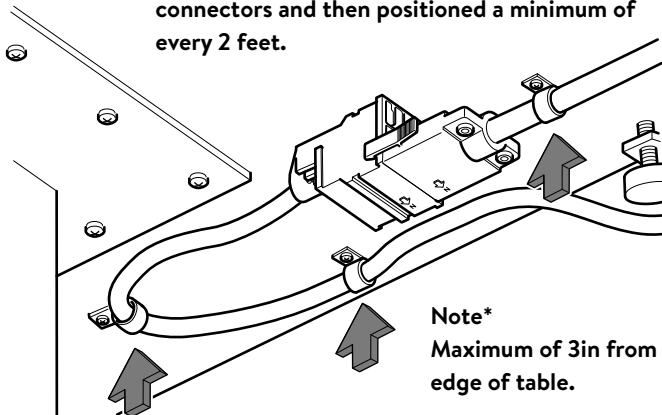

**Note\***  
Maximum of 3in from edge of table.

**Note\***  
The cord shall not hang down more than 6 inches below the underside of the table.

#### 5 Install Connector End of Power In-Feed into 3-port Connector on any Power Module.

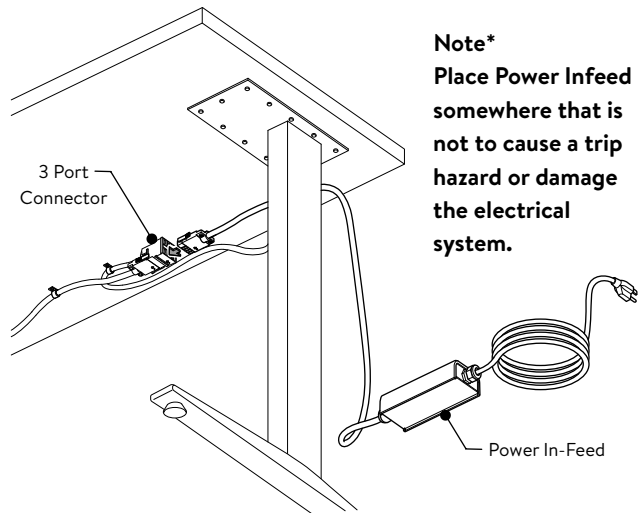

**Note\***  
Place Power Infeed somewhere that is not to cause a trip hazard or damage the electrical system.

**Note\***  
Never use more than one Power In-feed.

#### 6 Insert NEMA 5-15 Plug into a properly wired/grounded (Non GFCI) Standard Wall Outlet

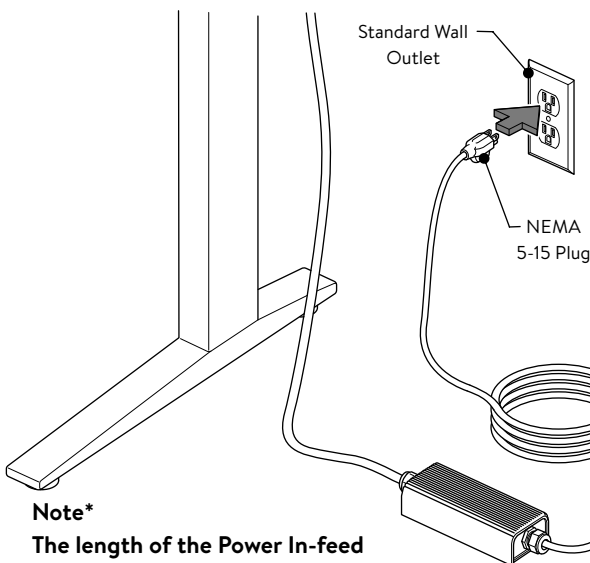

**Note\***  
The length of the Power In-feed NEMA cord as specified in our Condition of Accountability: Minimum 9 feet and a Maximum length of 15 feet.

#### 7 Verify that LED is green on the Power In-feed

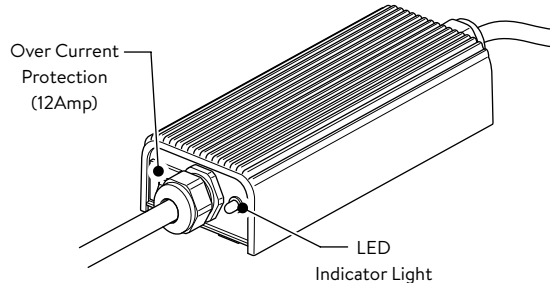

#### (Light Status)

GREEN	RED	Possible Cause
● Off	⦿ Flashing	More than one Power In-feed connected to system.
● Off	○ On	Exceeds maximum number of Power modules
○ On	● Off	If no power check that circuit breaker has not opened. (Max current load is 12Amps)