

GROMMET INSTALLATION

Components & Hardware

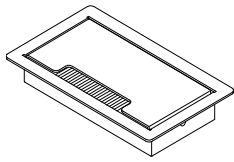

(A) Grommet*
Qty 1



(B) Mounting Screw
#6 x 1/2
Qty 2

Tools Needed



* VIL-GROM-F shown

- 1-** Determine the surface cutout for the Grommet (A) version being installed and prepare the surface.
Note: Refer to chart to determine X, Y & R dimensions.
- 2-** Insert the Grommet into the cutout from above.
- 3-** While pressing Grommet firmly to surface, insert Mounting Screws (B) through side holes, as shown, and into side of cutout in work surface. Note: Use care to not damage work surface
- 4-** Ensure lid pivots freely through the entire motion.

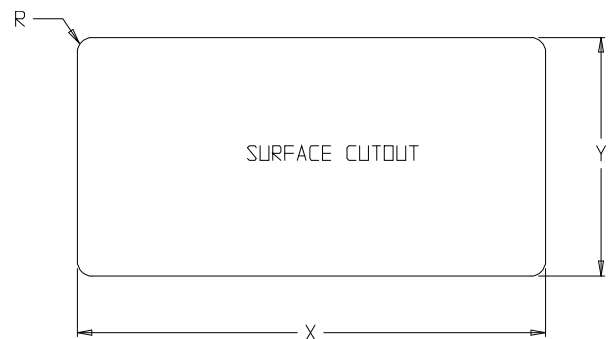

Model	VIL-GROM	VIL-GROM-LG	HID-GROM-S	HID-GROM-L
X Dim.	5.25"	8.00"	6.30"	9.25"
Y Dim.	3.00"	4.00"	5.30"	5.30"
R Dim.	.125"	.25"	.125"	.125"

