



7310 Innovation Blvd., Suite 104,
Fort Wayne, IN 46818
Customer Service: 800.829.3101

Powered by Pent®
ASHLEY 202
- Corded -
Above Worksurface Mounting
Installation Instruction

This device complies with part 15A of the FCC Rules. Operation is subject to the following two conditions: (1) This device may not cause harmful interference, and (2) this device must accept any interference received, including interference that may cause undesired operation.

Tools Required

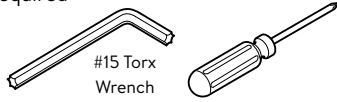

SPECIAL NOTE *

Optional data port options will need to be purchased from L-COM. L-COM part numbers have been provided in step #2.

1 Remove Data Port Cover

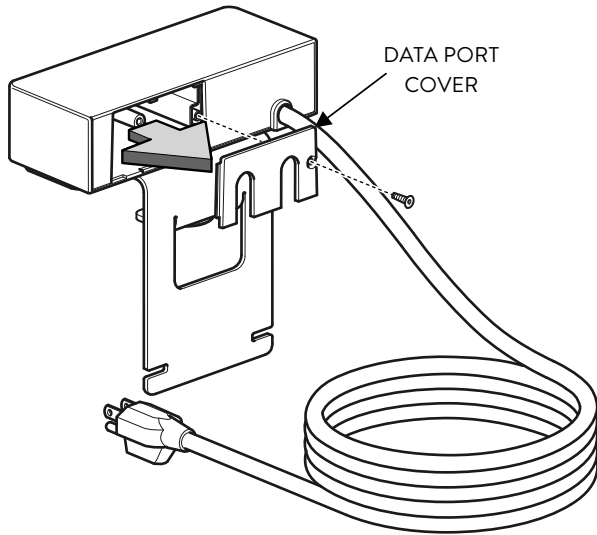

2 Install Data Port Options (VGA, RJ45, HDMI, BLANK)

NOTE
See Sheet #2 for Detailed Instructions

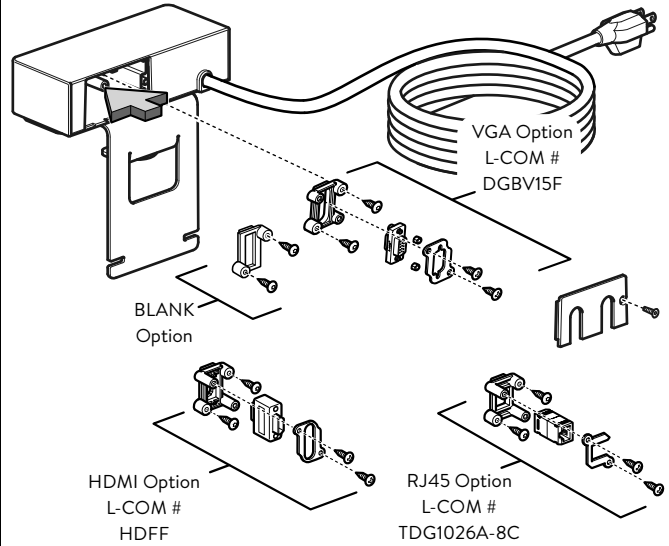

3 Slide Bracket Behind Worksurface

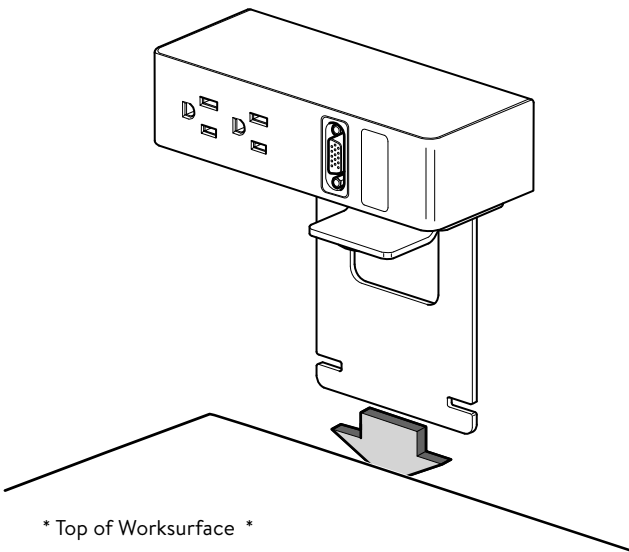

* Top of Worksurface *

4 Install Bottom Bracket Under the Worksurface

* Underside of Worksurface *

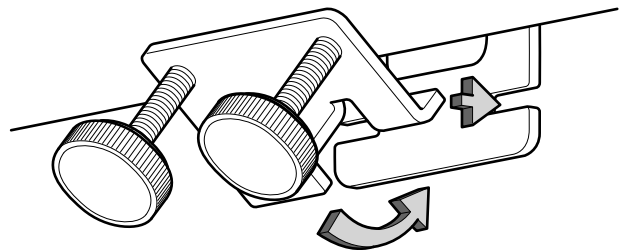



7310 Innovation Blvd., Suite 104,
Fort Wayne, IN 46818
Customer Service: 800.829.3101

Powered by Pent®
ASHLEY 202
- Corded -
Above Worksurface Mounting
Installation Instruction

This device complies with part 15A of the FCC Rules. Operation is subject to the following two conditions: (1) This device may not cause harmful interference, and (2) this device must accept any interference received, including interference that may cause undesired operation.

Tools Required

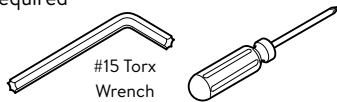

2.1 Install VGA Option (L-COM# DGBV15F)

A Remove Nuts from VGA Connector

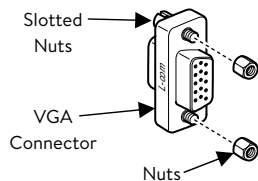

B Install Bracket to Connector

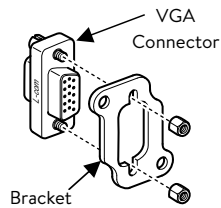

C Install Components into Body of Unit

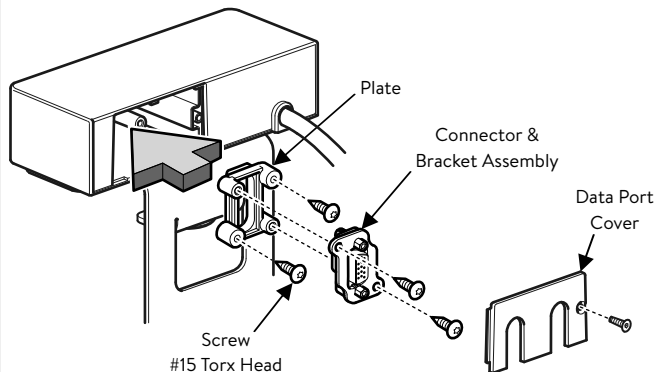

2.2 Install RJ45 Option (L-COM# TDG1026A-8C)

A Mate Angled Surfaces of Plate and Connector

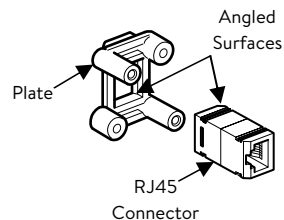

B Install Bracket

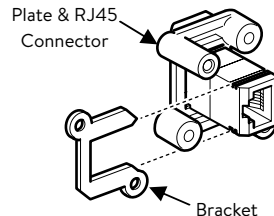

C Install Components into Body of Unit

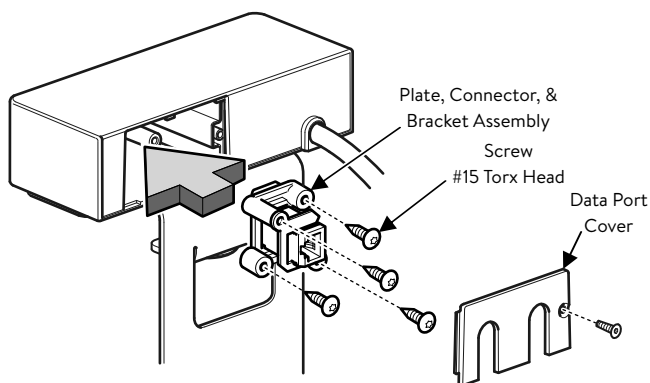

2.3 Install HDMI Option (L-COM# HDFS)

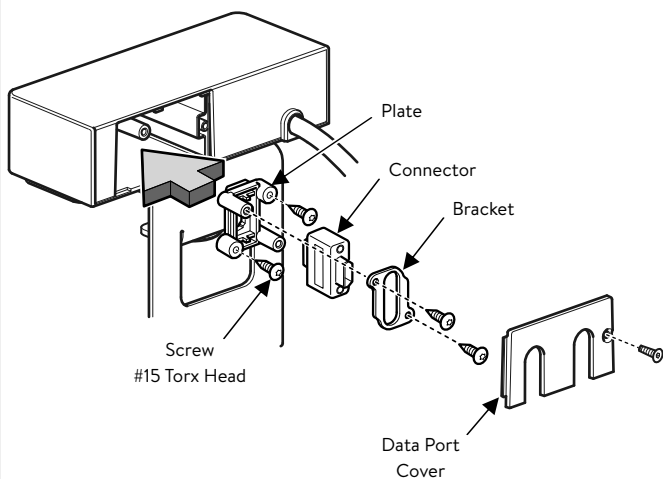

2.4 Install BLANK Option

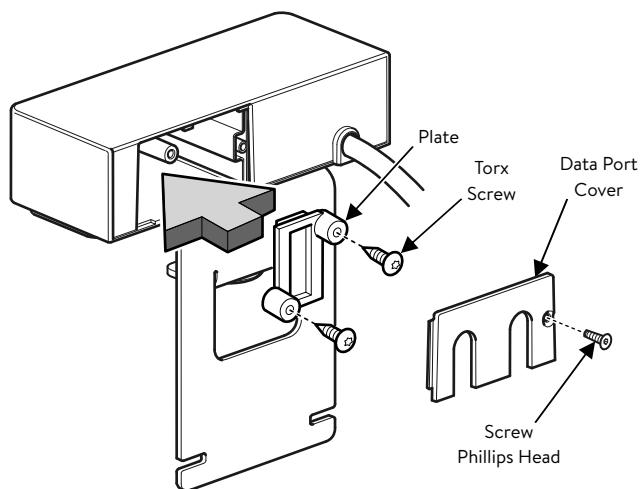



7310 Innovation Blvd., Suite 104,
Fort Wayne, IN 46818
Customer Service: 800.829.3101

Powered by Pent®
ASHLEY 202
- Corded -
Above Worksurface Mounting
Installation Instruction

This device complies with part 15A of the FCC Rules. Operation is subject to the following two conditions: (1) This device may not cause harmful interference, and (2) this device must accept any interference received, including interference that may cause undesired operation.

Tools Required



#15 Torx
Wrench

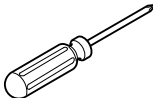

Screwdriver needed for optional
power cord mounting clamps.

5 Secure Thumb Screws and Route Power Cord Option
to Nearest Power Distribution Source

(A)

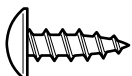

#8 x 1/2" Pan Head Screw

* Underside of Worksurface *

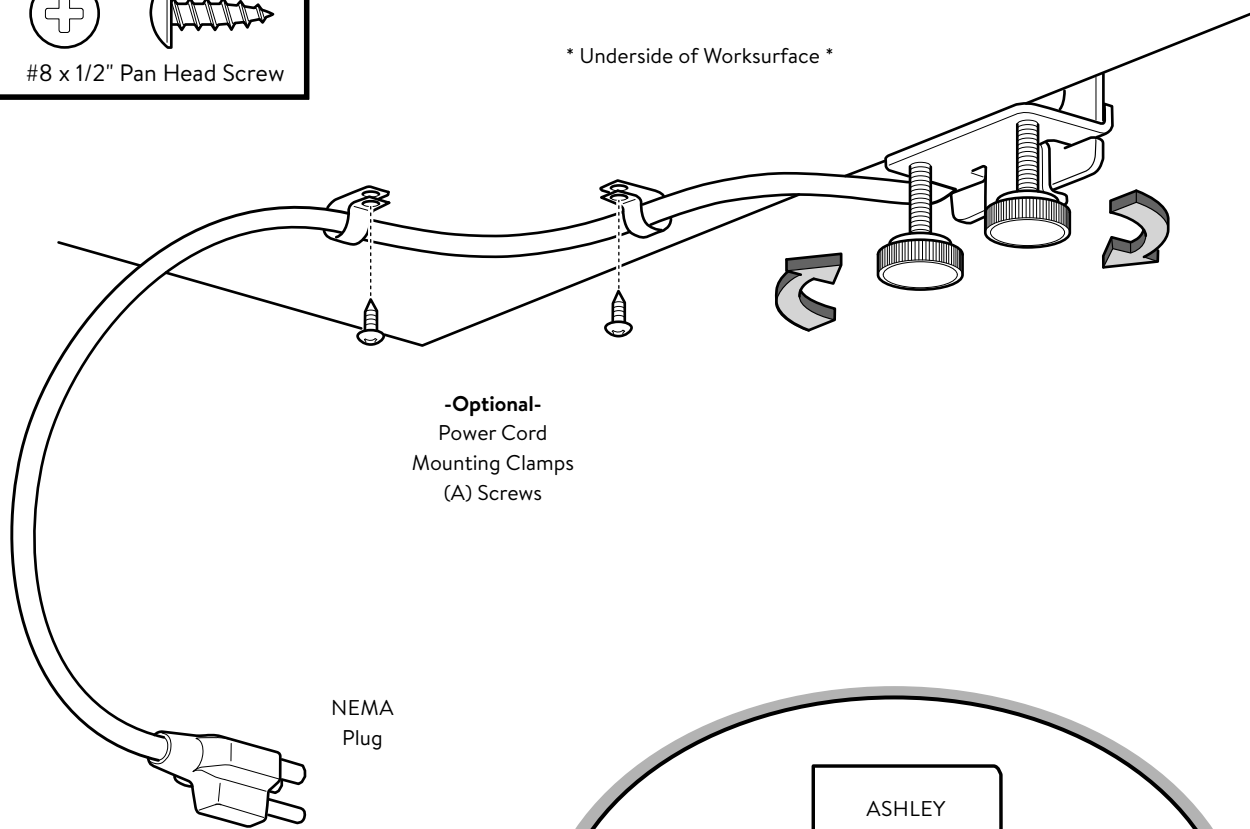

-Optional-
Power Cord
Mounting Clamps
(A) Screws

NEMA
Plug

Worksurface
Thickness Range
(3/4" to 1-1/2")

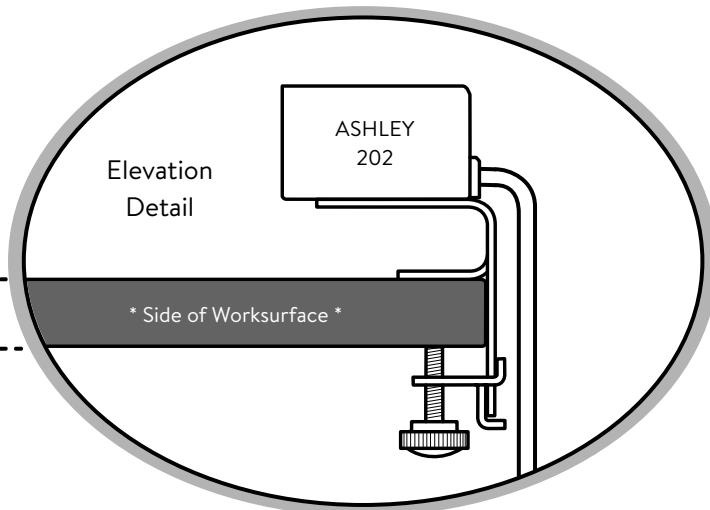

Elevation
Detail

ASHLEY
202

* Side of Worksurface *