

4|2 System

Power Distribution System Installation Instruction

This device complies with part 15A of the FCC Rules. Operation is subject to the following two conditions: (1) This device may not cause harmful interference, and (2) this device must accept any interference received, including interference that may cause undesired operation.

System Components

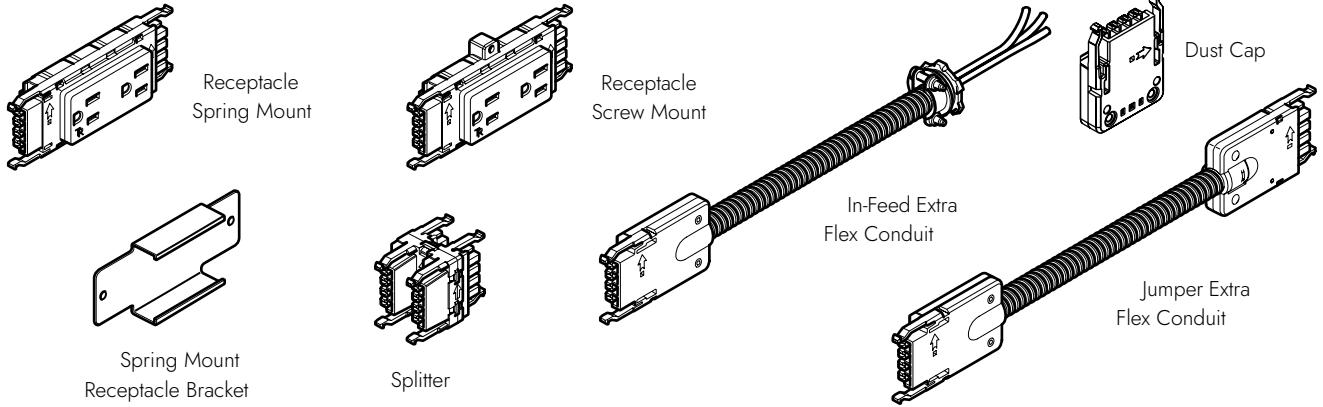

*** NOTE ***

The 4|2 System has been evaluated to prevent inadvertent contact with live parts. Unused connector openings are not required to be capped.

General Notes for 4|2 System Installations

The Receptacle Assembly is to be mechanically attached to a Beam, Panel Base, Table or Wall. It serves to provide the point of attachment and electrical connection for flexible panel connectors, i.e. Jumpers, multi-port connectors, i.e. Splitters and power entry components, i.e. In-Feeds.

1. Access covers must be removed or opened to allow installation of Electrical Distribution Components.
2. Mechanically attach the Receptacle Assembly to the unit using attachment means supplied with the panel furniture system or Components.
3. Depending on the type of attachment means, it may be most convenient to attach the Electrical Distribution Components before the furniture is assembled.
4. When Installation utilizes splitters, support is required in the middle of these sections that create lengths greater than 6 feet.

*** NOTE ***

A licensed electrician must make the hardwire connections in accordance with all local codes and regulations.



*** WARNING ***
Risk of electrical shock!

It is possible for this office furnishing system to be connected to more than one source of supply. Disconnect all sources prior to any servicing. A single circuit shall not be powered by more than one source.

1 Connect Multiple Receptacles either Inline or Inline Offset.

*** NOTE ***

Be sure parts are fully seated together to assure proper electrical connection and mechanical security. Spring Mount Receptacles not shown but connect the same way.

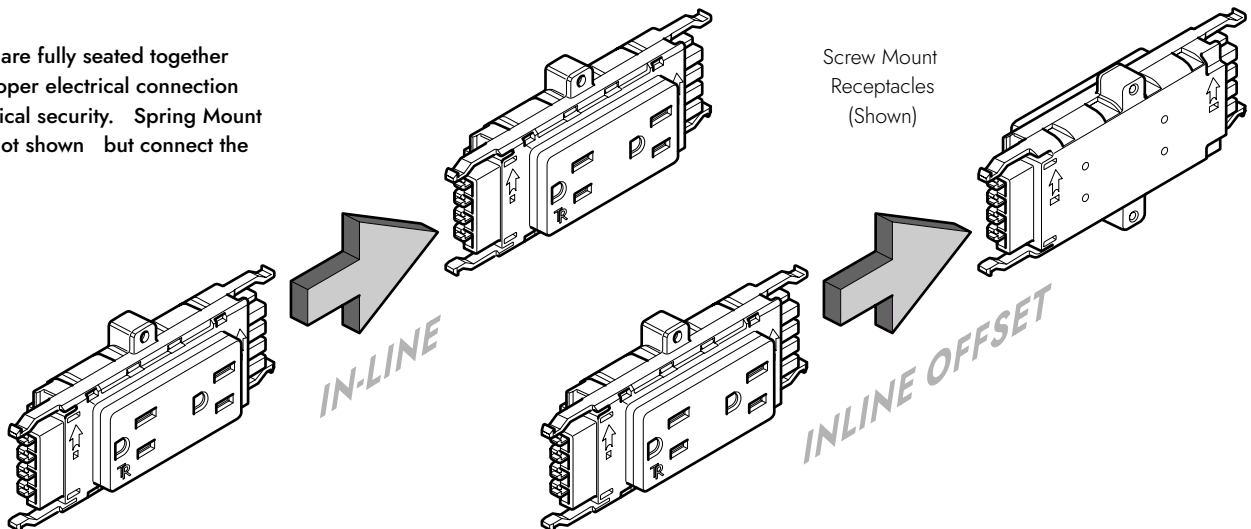

2A

For Spring Mount Receptacle Installation, Install the Spring Mount Receptacle Bracket in the desired location with the screws provided.

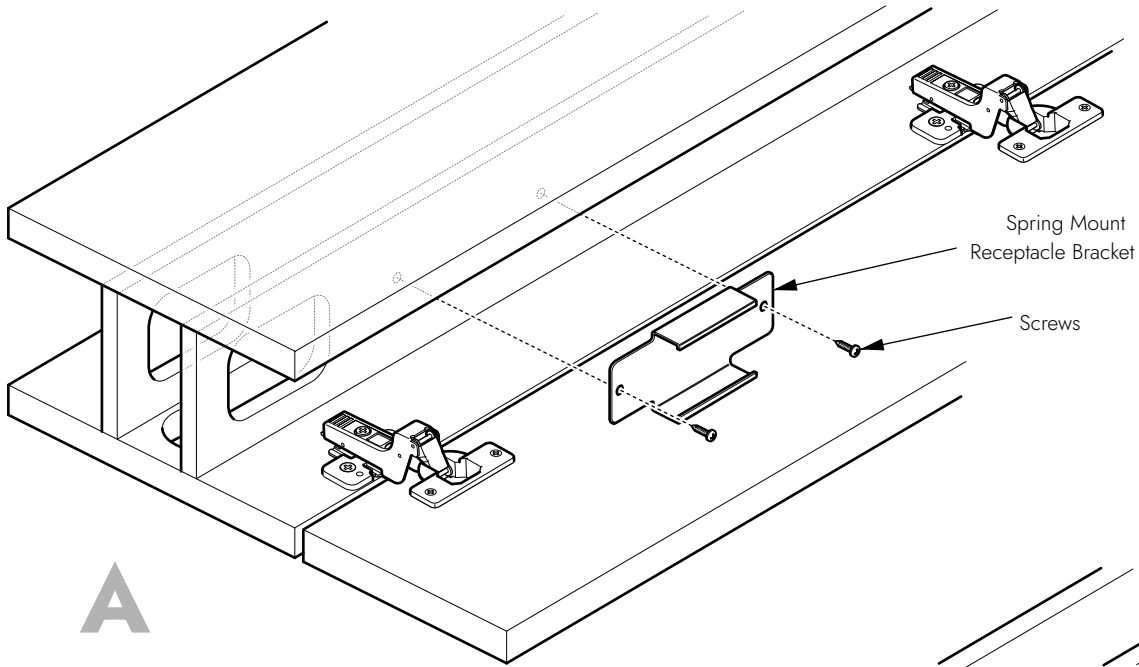

· NOTE *
Spring Mount Receptacle will "CLICK" into Spring Mount Receptacle Bracket.

BEAM EXAMPLE
SHOWN

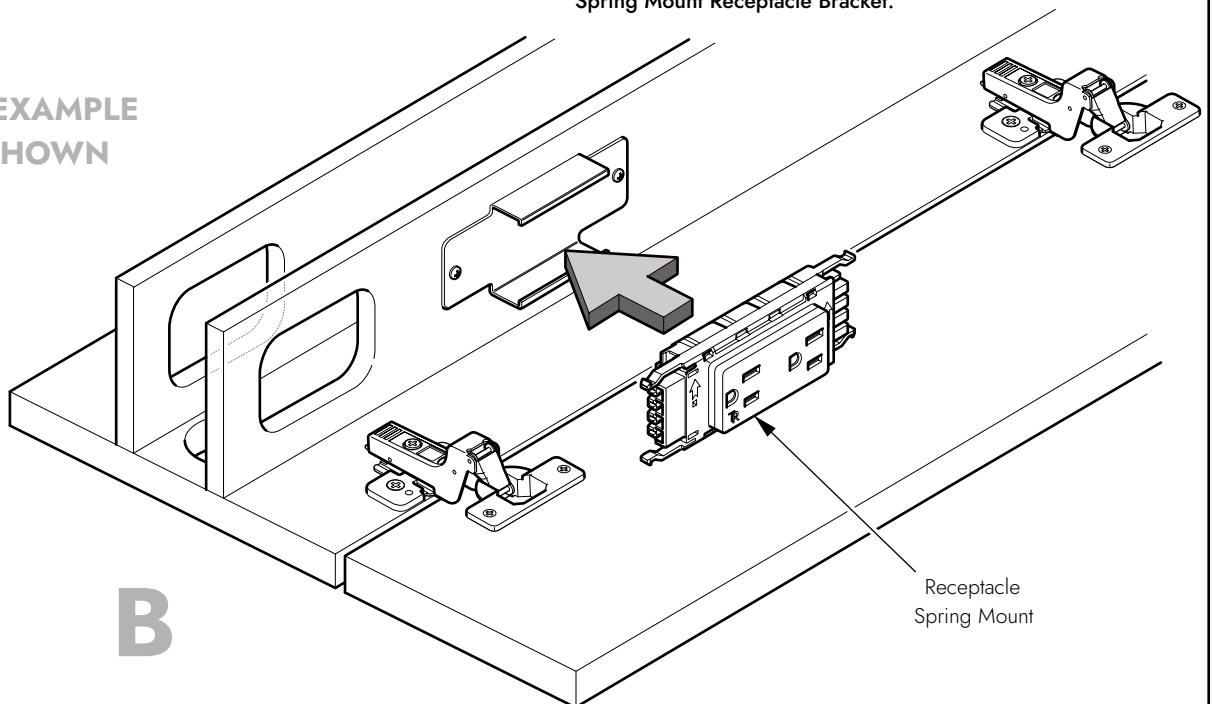

2B

For Screw Mount Receptacle Installation, Install the Screw Mount Receptacle in the desired location with the screws.

*** NOTE ***

#6 Screws Recommended But Not Supplied. (These could be Wood, Sheet Metal, etc. - Any Drive Type - all depends on the type of material attaching Receptacle to)

A

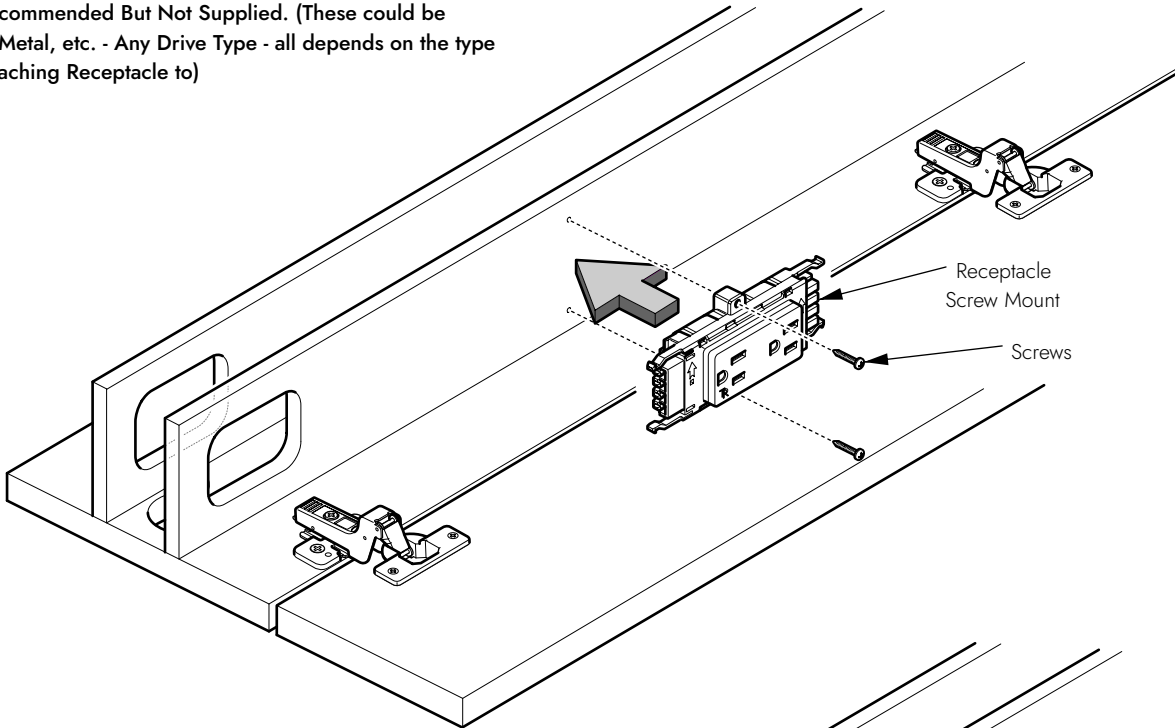

BEAM EXAMPLE SHOWN

B

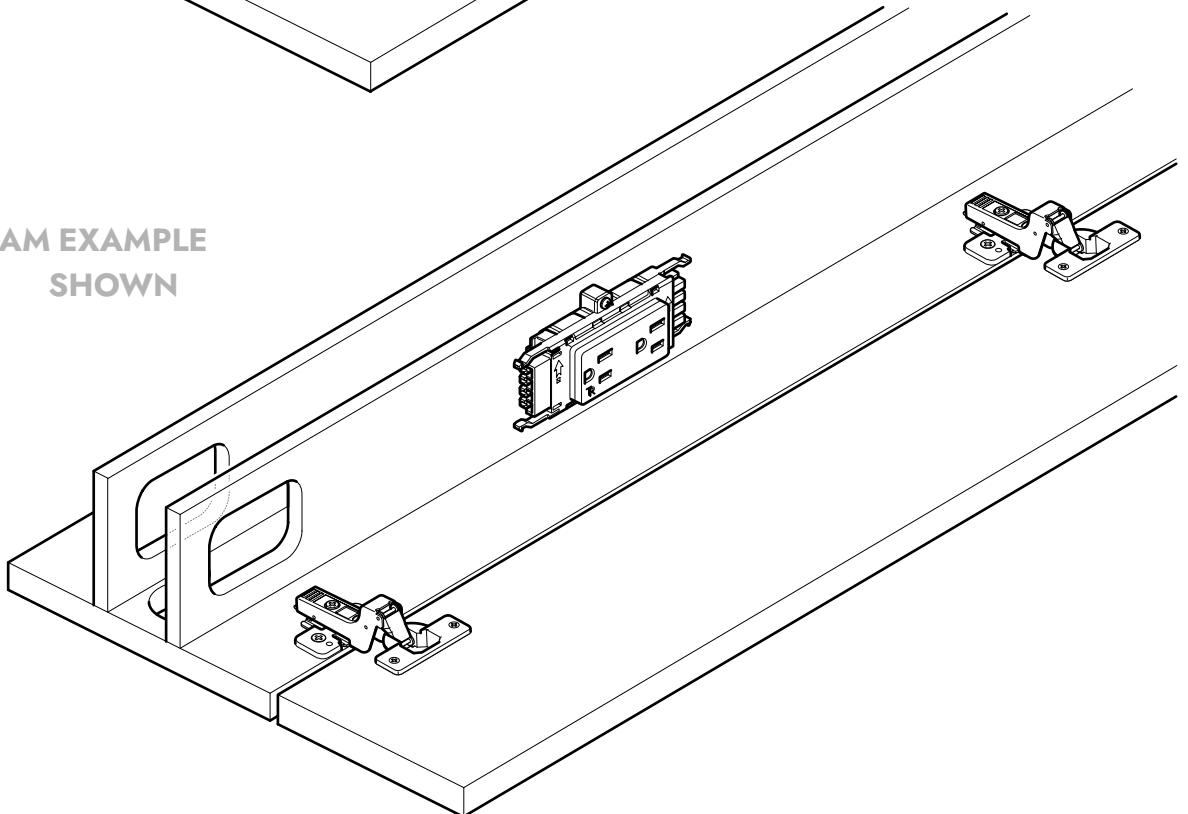

3 Connect Conduit In-Feed or Conduit Jumper to Receptacles.

*** NOTE ***

Be sure parts are fully seated together to assure proper electrical connection and mechanical security.

*** NOTE ***

An Electrician must hook-up the In-Feed to the Building Power - or "Hard Wire" it.

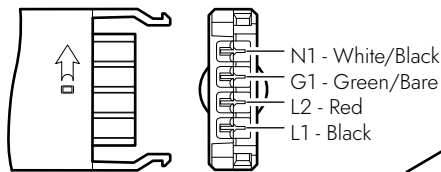

WIRING ORDER
 4 - Wire
 2 - 1 - 1
 Shared Neutral

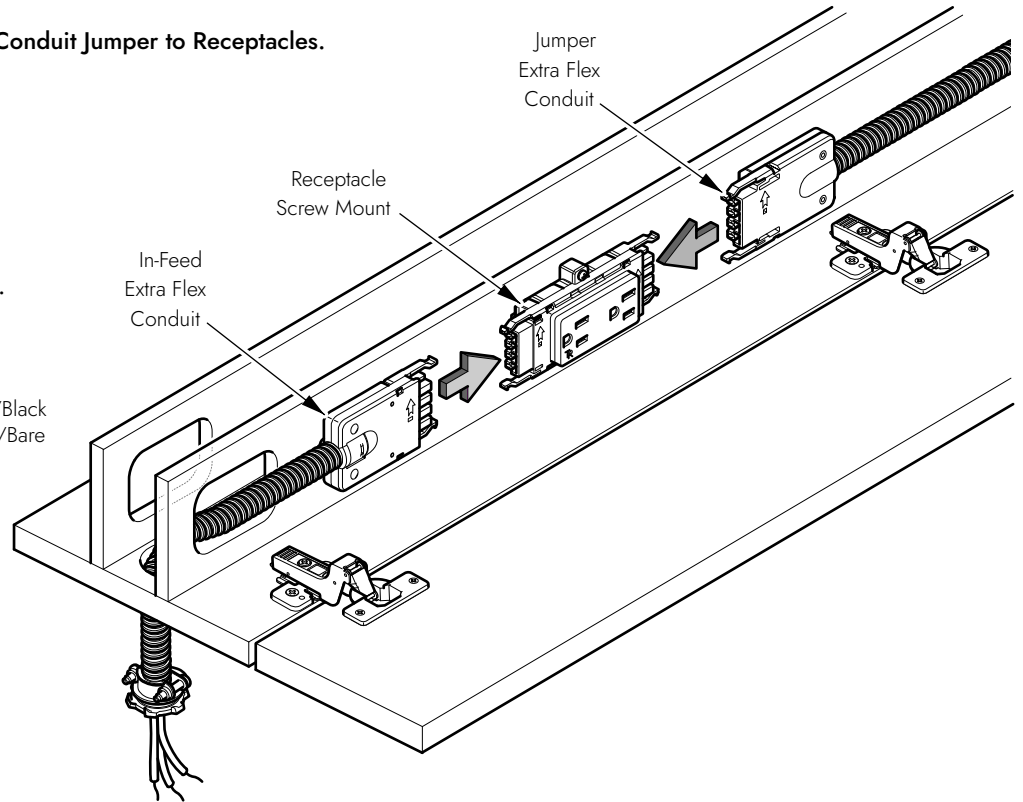

4 Install Splitter between In-Feeds, Jumpers, and Receptacles.

*** NOTE ***

Be sure parts are fully seated together to assure proper electrical connection and mechanical security.

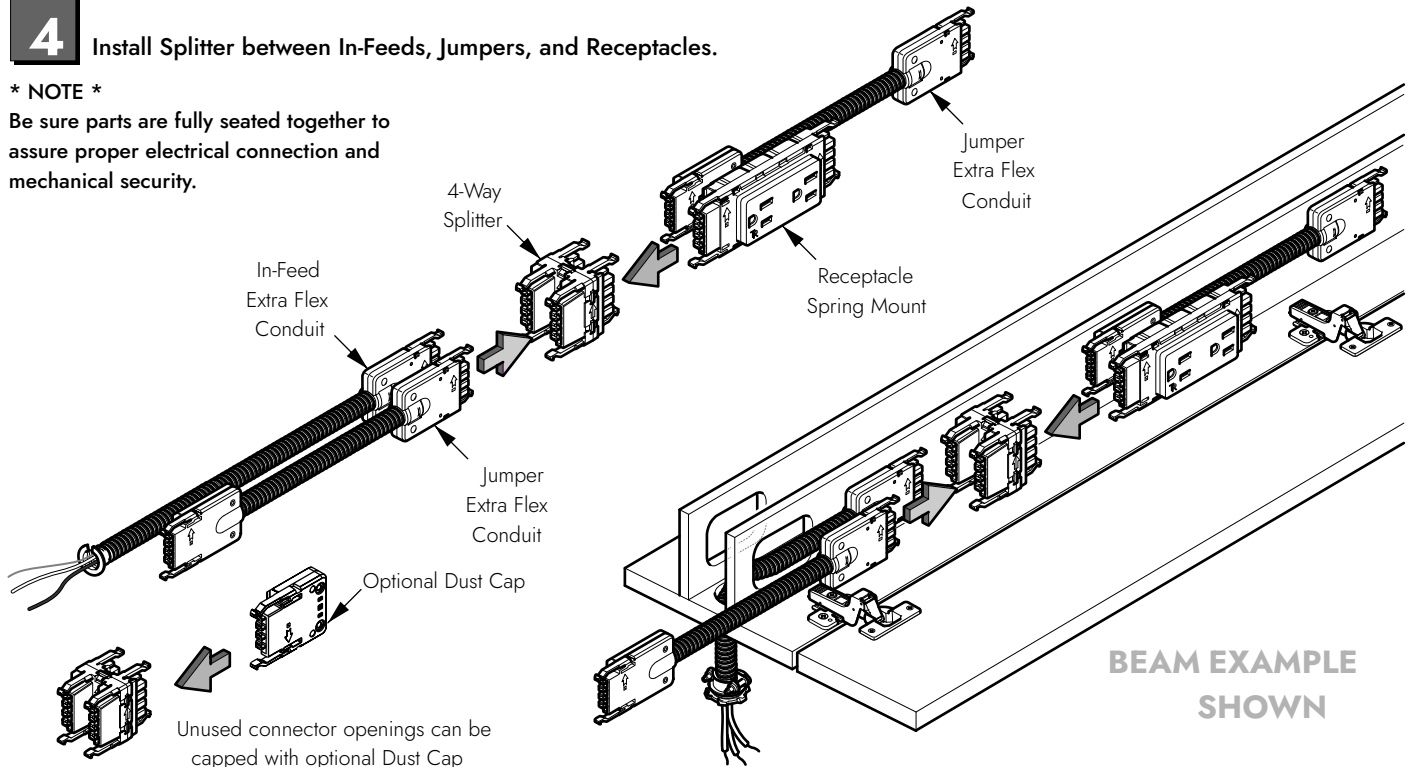

BEAM EXAMPLE SHOWN